

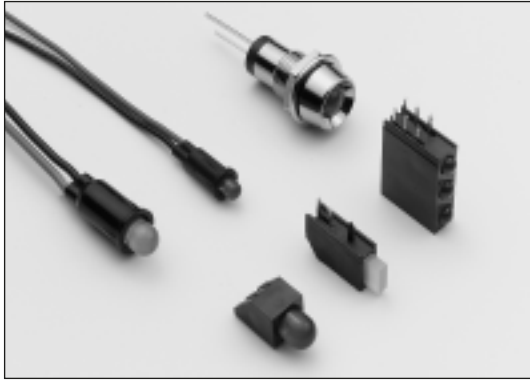

# LED Assemblies



A full range of LED holders with a wide range of available LED's. This range includes 3.00 and 5.00mm LED models for SMD mounting, 2mm multi-station subminiature and panel mount models. All of the LED holders as published in the first nineteen pages of this chapter can be supplied assembled with LED's.

## ■ 3.00mm(T1), 90° SMD assembly

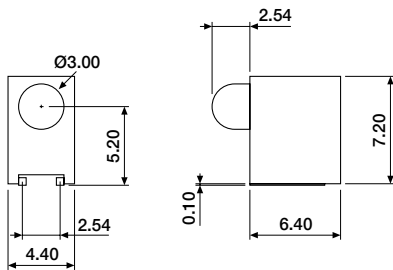

Pad Size = 1.00 x 5.80mm

### ORDERING INFORMATION

BVO-8500-0000-XXXXXX

see last pages of this chapter

Contact sales office for tape and reel assemblies.

## ■ 5.00mm(T1<sup>3/4</sup>), 90° SMD assembly

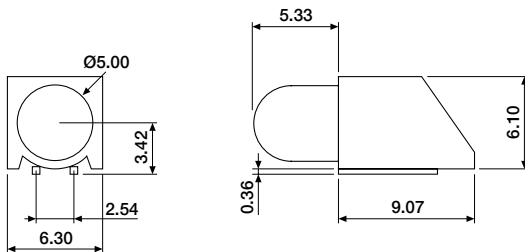

Pad Size = 1.00 x 5.80mm

### ORDERING INFORMATION

BVO-8510-0000-XXXXXX

see last pages of this chapter

Contact sales office for tape and reel assemblies.

## ■ 3.00mm(T1), panel mount, nylon

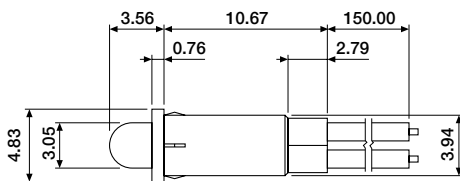

Panel Hole Size = Ø3.84mm

### ORDERING INFORMATION

BVO-8700-0000-XXXXXX

BVO-8700-1000-XXXXXX with 15.00cm AWG 24 wires

see last pages of this chapter



## ■ 3.00mm(T1), panel mount, nylon

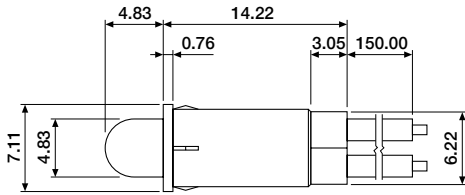

Panel Hole Size = Ø6.35mm

### ORDERING INFORMATION

**BVO-8710-0000-XXXXXX**

**BVO-8710-1000-XXXXXX** with 15.00cm AWG 24 wires

see last pages of this chapter

## ■ 3.00mm(T1), panel mount, nickel plated brass

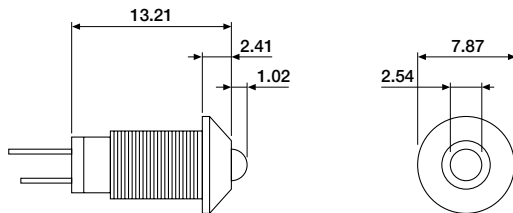

Style A

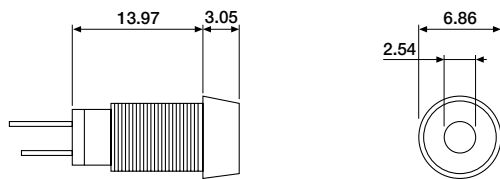

Style B

### ORDERING INFORMATION

**BVO-8900-0000-XXXXXX** style A

**BVO-8900-1000-XXXXXX** style B

see last pages of this chapter

All models will be supplied with a stainless steel nut and lock washer.

## ■ 5.00mm(T1<sup>3/4</sup>), panel mount, nickel plated brass

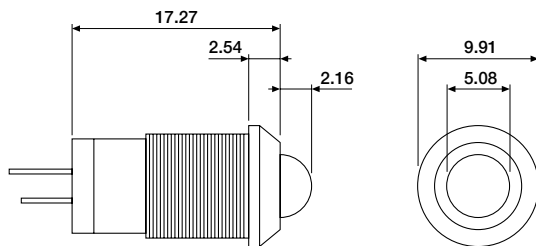

Style A

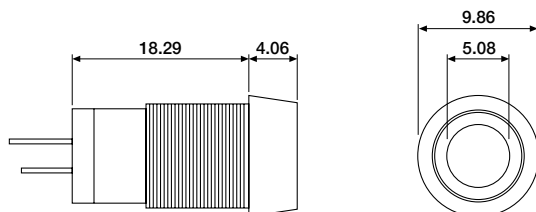

Style B

### ORDERING INFORMATION

**BVO-8910-0000-XXXXXX** style A

**BVO-8910-1000-XXXXXX** style B

see last pages of this chapter

All models will be supplied with a stainless steel nut and lock washer.



## ■ 2.00mm sub-miniature

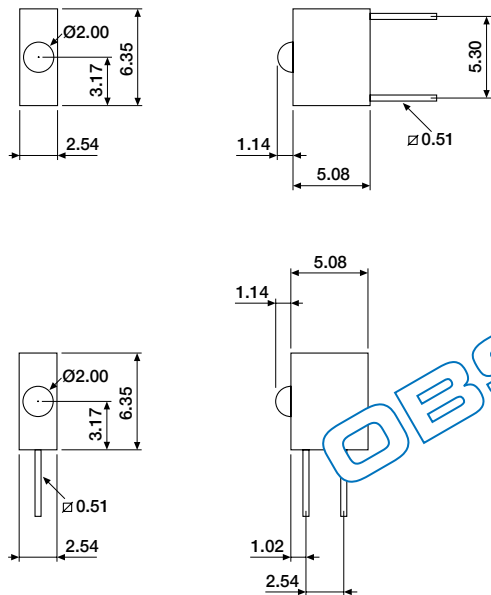

### ORDERING INFORMATION

BVO-9100-0000-XXXXXX straight  
BVO-9100-1000-XXXXXX right-angle

see last pages of this chapter

## ■ 2.00mm sub-miniature, tri-level

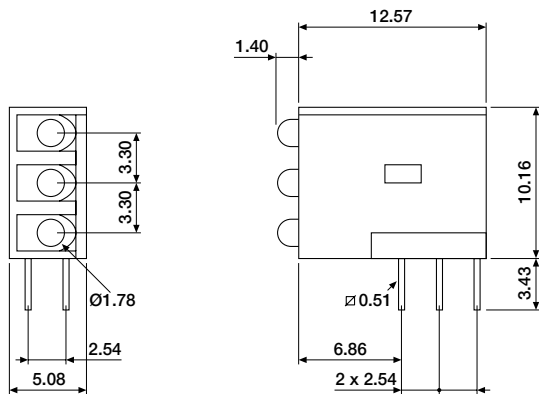

### ORDERING INFORMATION

BVO-9110-0000-XXXXXX DIN 41494 compatible

Contact sales office for order No's

## ■ 2.00mm sub-miniature, quad-level

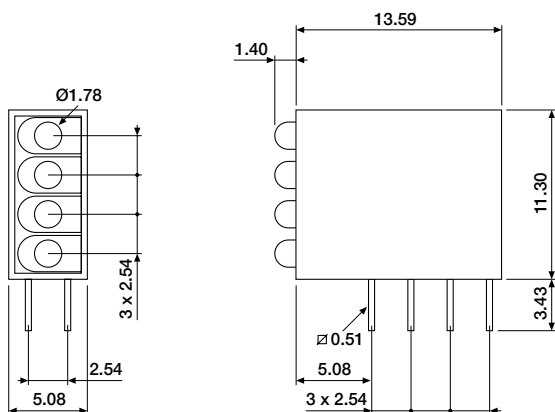

### ORDERING INFORMATION

BVO-9120-0000-XXXXXX

Contact sales office for order No's



## ■ 2.00mm sub-miniature, quad level, rectangular

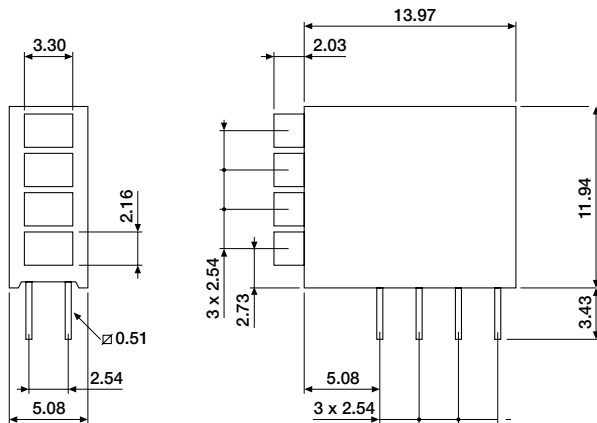

### ORDERING INFORMATION

BVO-9130-0000-XXXXXX DIN 41494 compatible

contact sales office for order No's

## ■ Ordering information for 1 station models, 3.00mm (T1) and 5.00mm (T1<sup>3/4</sup>)

BVO-XXXX-XXXX-XXXXXX

#### options

00 for standard  
40 for blinking  
71 for uncut leads

01 for low current  
60 for red anode  
90 for rev. polarity

05 for 5 volt  
61 for red cathode

12 for 12 volt  
70 for cut leads

#### lens

00 for diffused

11 for water clear

22 for tinted,  
non-diffused

23 for white

#### colour

20 for red

21 for super red

22 for HE red

24 for ultra red

30 for orange,  
(amber)

31 for super orange

34 for ultra orange

40 for yellow

41 for super yellow

44 for ultra yellow

50 for green

51 for super green

52 for HE green

53 for pure green

60 for blue

61 for super blue

90 for white

25 for red/green

45 for yellow/green

Order No. as used with BIV Series, pages 11.02 to 11.19

Contact sales office for order numbers of 2 and more stations.