

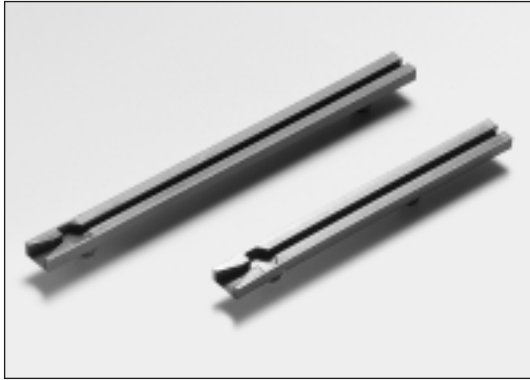

Rack & Panel Card Guides, Standard & Flame Retardant

For 1.60mm PCB's



Choose from 24 standard lengths and pick your density and air circulation pattern. Place guides just where you want. Guide installation is a snap into any type of sheet, plate or channel. Retention is firm and no special tooling is required. Card insertion is fast and easy with funnelled ramps. No more insertion hang ups. Locking ejectors can be used for positive card retention and insertion/extraction ease. All card guides can be supplied with a stainless steel card insert for EMI/RFI protection.

Panel Thickness : 1.19 to 2.29mm.

Material : Glass reinforced Nylon, UL 94V-0 (standard)
 : Flame retardant Nylon, UL 94V-0 (flame retardant)
 Colour : Black (standard)
 : Brownish-red (flame retardant)

■ Lengths 50.80 to 203.20mm, standard

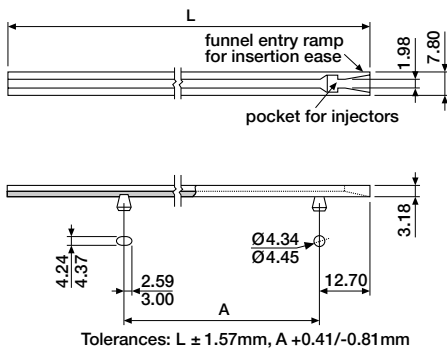

ORDERING INFORMATION

BIV-200X-XXXX*	A = 25.80 if XXXX = 0400
BIV-201X-XXXX*	A = 38.51 if XXXX = 0500 to 0700
BIV-202X-XXXX*	A = 76.61 if XXXX = 0800 to 1100
BIV-203X-XXXX*	A = 127.41 if XXXX = 1200 to 1300
BIV-204X-XXXX*	A = 153.19 if XXXX = 1400 to 1600

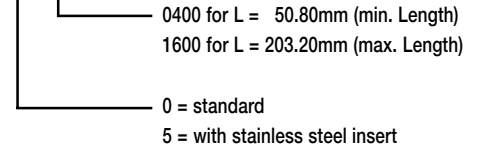

*For each increment of 12.70mm the last four digits of the order number must be increased by 100.

■ Lengths 215.90 to 355.60mm, standard

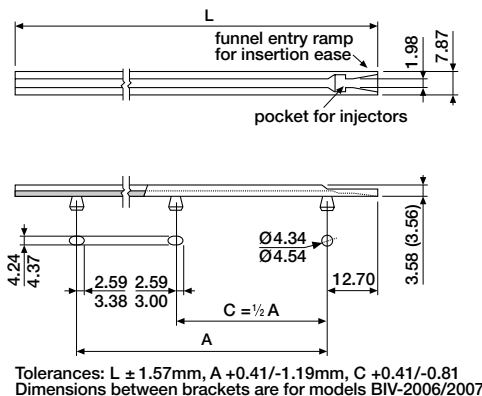

ORDERING INFORMATION

BIV-205X-XXXX*	A = 191.29 if XXXX = 1700 - 1900
BIV-206X-XXXX*	A = 229.39 if XXXX = 2000 - 2200
BIV-207X-XXXX*	A = 267.89 if XXXX = 2300 - 2500
BIV-208X-XXXX*	A = 305.99 if XXXX = 2600 - 2800

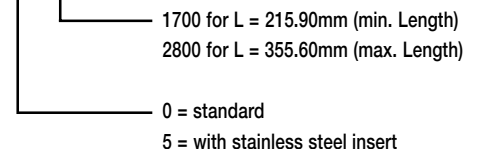

*For each increment of 12.70mm the last four digits of the order number must be increased by 100.

Note : Slotting or elongating of second and third mounting holes is recommended to allow for length variations in molding and assembly ease



Rack & Panel Card Guides, Standard & Flame Retardant

For 1.60mm PCB's

■ Lengths 50.01 to 200.03mm, flame retardant

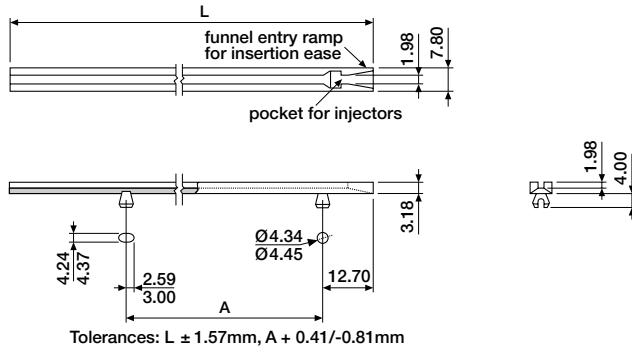

ORDERING INFORMATION

BIV-210X-XXXX*	A = 24.99 if XXXX = 0400
BIV-211X-XXXX*	A = 37.69 if XXXX = 0500 to 0700
BIV-212X-XXXX*	A = 75.41 if XXXX = 0800 to 1100
BIV-213X-XXXX*	A = 125.81 if XXXX = 1200 to 1300
BIV-214X-XXXX*	A = 151.61 if XXXX = 1400 to 1600

0400 for L = 50.01mm (min. Length)
1600 for L = 200.03mm (max. Length)

0 = standard
5 = with stainless steel insert

*For each increment of 12.70mm the last four digits of the order number must be increased by 100.

■ Lengths 212.73 to 350.82mm, flame retardant

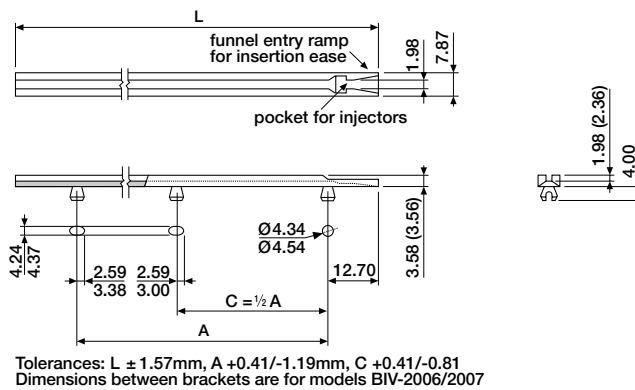

ORDERING INFORMATION

BIV-215X-XXXX*	A = 189.71 if XXXX = 1700 to 1900
BIV-216X-XXXX*	A = 227.03 if XXXX = 2000 to 2200
BIV-217X-XXXX*	A = 264.31 if XXXX = 2300 to 2500
BIV-218X-XXXX*	A = 302.41 if XXXX = 2600 to 2800

1700 for L = 212.73mm (min. Length)
2800 for L = 350.82mm (max. Length)

0 = standard
5 = with stainless steel insert

*For each increment of 12.70mm the last four digits of the order number must be increased by 100.