

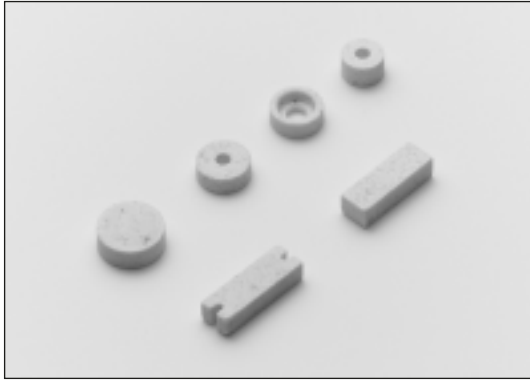

Wash Away Spacers



These unique, easy to use spacers are ideal for fast and accurate component placement. Designed for wave, dip and hand soldering use, Wash-Away spacers precisely space components then dissolve quickly without a trace of residue. These spacers dissolve in warm or hot running water, usually within a minute. The dissolving time for any particular spacer is dependent on water temperature, pressure and mass and shape of the pad. Compounded of organic materials, they are non-corrosive, conductive, allergenic and will not stain components or boards.

Note : Most Wash-Away Spacers may be ordered in an effervescent version to reduce dissolving time. Contact sales office for order information.

■ Circular

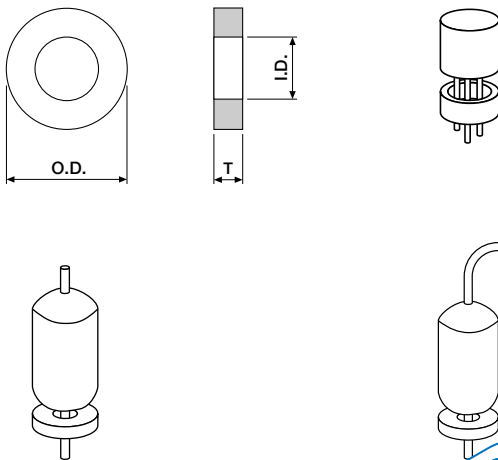

ORDERING INFORMATION & DIMENSIONS

| Order Number | I.D. | O.D. | Available Thickness = XXXX | | | | | | | | | |
|---------------|------|-------|----------------------------|------|------|------|------|------|------|------|------|------|
| | | | 0060 | 0080 | 0100 | 0120 | 0140 | 0180 | 0200 | 0240 | 0260 | 0300 |
| BWA-9010-XXXX | 1.02 | 2.16 | o | o | o | o | | | | | | |
| BWA-9011-XXXX | 1.14 | 2.54 | o | o | o | o | | | | | | |
| BWA-9064-XXXX | 1.14 | 3.56 | o | o | o | o | o | o | o | o | | |
| BWA-9040-XXXX | 1.14 | 3.96 | o | o | o | o | o | o | o | o | o | |
| BWA-9009-XXXX | 1.57 | 3.96 | o | o | o | o | o | o | o | o | o | |
| BWA-9016-XXXX | 1.78 | 4.75 | o | o | o | o | o | o | o | o | o | |
| BWA-9014-XXXX | 1.91 | 3.56 | o | o | o | o | o | o | o | o | o | |
| BWA-9007-XXXX | 1.91 | 4.45 | o | o | o | o | o | o | o | o | o | |
| BWA-9046-XXXX | 2.29 | 6.35 | o | o | o | o | o | o | o | o | o | |
| BWA-9023-XXXX | 2.29 | 7.87 | o | o | o | o | o | o | o | o | o | |
| BWA-9024-XXXX | 2.29 | 8.64 | o | o | o | o | o | o | o | o | o | |
| BWA-9016-XXXX | 3.18 | 5.21 | o | o | o | o | o | o | o | o | o | |
| BWA-9018-XXXX | 3.18 | 6.35 | o | o | o | o | o | o | o | o | o | o |
| BWA-9027-XXXX | 3.18 | 7.37 | o | o | o | o | o | o | o | o | o | |
| BWA-9041-XXXX | 3.96 | 9.14 | o | o | o | o | o | o | o | o | o | |
| BWA-9017-XXXX | 4.32 | 6.35 | o | o | o | o | o | o | o | o | o | |
| BWA-9028-XXXX | 4.37 | 8.71 | o | o | o | o | o | o | o | o | o | |
| BWA-9025-XXXX | 4.57 | 12.19 | o | o | o | o | o | o | o | o | o | |
| BWA-9013-XXXX | 5.72 | 7.87 | o | o | o | o | o | o | o | o | o | |
| BWA-9005-XXXX | 5.72 | 9.53 | o | o | o | o | o | o | o | o | o | o |
| BWA-9022-XXXX | 5.72 | 11.10 | o | o | o | o | o | o | o | o | o | |
| BWA-9006-XXXX | 6.35 | 9.53 | o | o | o | o | o | o | o | o | o | |
| BWA-9042-XXXX | 6.35 | 11.13 | o | o | o | o | o | o | o | o | o | |
| BWA-9019-XXXX | 6.35 | 12.19 | o | o | o | o | o | o | o | o | o | |
| BWA-9030-XXXX | 6.99 | 10.08 | o | o | o | o | o | o | o | o | o | |
| BWA-9009-XXXX | 7.62 | 11.10 | o | o | o | o | o | o | o | o | o | o |

0060 = 0,03" = 0.76mm = min. height
0300 = 0,15" = 3.81mm = max. height

■ Concave

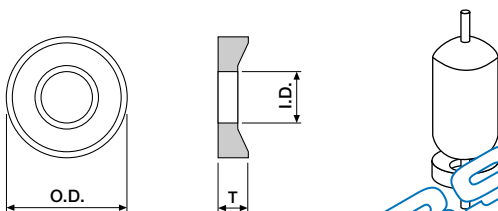

ORDERING INFORMATION & DIMENSIONS

| Order Number | I.D. | O.D. | Available Thickness = XXXX | | | | | | | | | |
|---------------|------|------|----------------------------|------|------|------|------|------|------|------|------|------|
| | | | 0060 | 0100 | 0120 | 0140 | 0160 | 0180 | 0200 | 0240 | 0260 | 0300 |
| BWA-9068-XXXX | 1.14 | 2.79 | o | o | o | o | o | o | o | o | o | |
| BWA-9067-XXXX | 1.14 | 3.56 | o | o | o | o | o | o | o | o | o | |
| BWA-9020-XXXX | 3.18 | 7.36 | o | o | o | o | o | o | o | o | o | o |
| BWA-9012-XXXX | 3.18 | 7.87 | o | o | o | o | o | o | o | o | o | |

0060 = 0,03" = 0.76mm = min. height
0300 = 0,15" = 3.81mm = max. height



Wash Away Spacers

■ Slotted

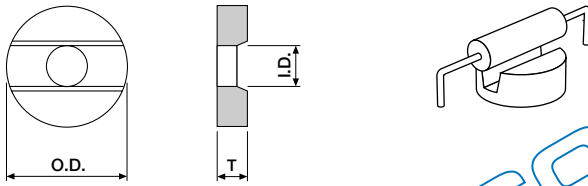

ORDERING INFORMATION & DIMENSIONS

| Order Number | I.D. | O.D. | Available Thickness = XXXX | | | | | | | | | | |
|---------------|------|-------|----------------------------|------|------|------|------|------|------|------|------|------|---|
| | | | 0100 | 0120 | 0140 | 0160 | 0180 | 0200 | 0240 | 0260 | 0280 | 0300 | |
| BWA-9037-XXXX | - | 3.96 | ○ | ○ | ○ | ○ | ○ | ○ | ○ | ○ | ○ | ○ | ○ |
| BWA-9036-XXXX | - | 4.75 | ○ | ○ | ○ | ○ | ○ | ○ | ○ | ○ | ○ | ○ | ○ |
| BWA-9021-XXXX | 3.18 | 6.35 | | | | | | ○ | ○ | ○ | ○ | ○ | ○ |
| BWA-9035-XXXX | - | 11.18 | | | | | | | | ○ | ○ | ○ | ○ |

0080 = 0,05" = 1.27mm = min. height
 0260 = 0,15" = 3.81mm = max. height

■ Solid

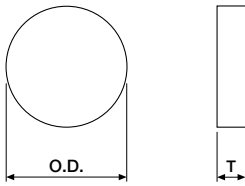

ORDERING INFORMATION & DIMENSIONS

| Order Number | O.D. | Available Thickness = XXXX | | | | | | | | |
|---------------|------|----------------------------|------|------|------|------|------|------|------|------|
| | | 0800 | 0100 | 0120 | 0140 | 0160 | 0180 | 0200 | 0240 | 0260 |
| BWA-9031-XXXX | 3.18 | ○ | ○ | ○ | ○ | ○ | ○ | ○ | ○ | ○ |
| BWA-9029-XXXX | 3.96 | ○ | ○ | ○ | ○ | ○ | ○ | ○ | ○ | ○ |
| BWA-9032-XXXX | 4.75 | ○ | ○ | ○ | ○ | ○ | ○ | ○ | ○ | ○ |
| BWA-9033-XXXX | 6.35 | ○ | ○ | ○ | ○ | ○ | ○ | ○ | ○ | ○ |
| BWA-9034-XXXX | 9.53 | ○ | ○ | ○ | ○ | ○ | ○ | ○ | ○ | ○ |

0080 = 0,04" = 1.02mm = min. height
 0260 = 0,13" = 3.30mm = max. height

■ Rectangular/square, solid

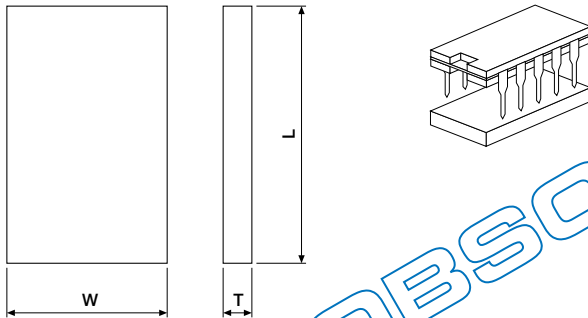

ORDERING INFORMATION & DIMENSIONS

| Order Number | L | W | Available Thickness = XXXX | | | | | | | | |
|---------------|-------|------|----------------------------|------|------|------|------|------|------|------|------|
| | | | 0080 | 0100 | 0120 | 0140 | 0180 | 0200 | 0240 | 0260 | 0300 |
| BWA-9120-XXXX | 2.16 | 2.16 | ○ | ○ | ○ | ○ | ○ | ○ | ○ | ○ | ○ |
| BWA-9121-XXXX | 2.41 | 2.41 | ○ | ○ | ○ | ○ | ○ | ○ | ○ | ○ | ○ |
| BWA-9102-XXXX | 12.83 | 4.06 | ○ | ○ | ○ | ○ | ○ | ○ | ○ | ○ | ○ |
| BWA-9101-XXXX | 14.27 | 4.70 | ○ | ○ | ○ | ○ | ○ | ○ | ○ | ○ | ○ |
| BWA-9117-XXXX | 16.92 | 7.14 | ○ | ○ | ○ | ○ | ○ | ○ | ○ | ○ | ○ |
| BWA-9116-XXXX | 16.92 | 7.62 | ○ | ○ | ○ | ○ | ○ | ○ | ○ | ○ | ○ |
| BWA-9100-XXXX | 17.02 | 2.54 | ○ | ○ | ○ | ○ | ○ | ○ | ○ | ○ | ○ |
| BWA-9118-XXXX | 17.91 | 6.60 | ○ | ○ | ○ | ○ | ○ | ○ | ○ | ○ | ○ |

0080 = 0,04" = 1.02mm = min. height
 0300 = 0,15" = 3.81mm = max. height

■ Rectangular, slotted

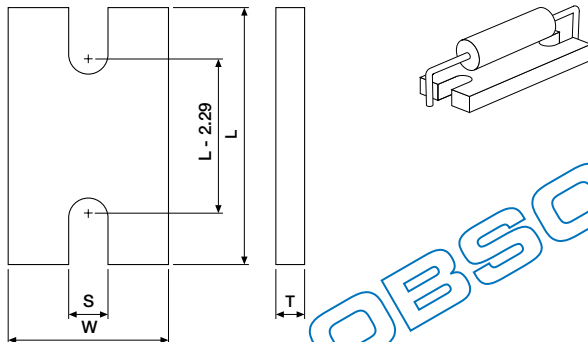

ORDERING INFORMATION & DIMENSIONS

| Order Number | L | W | S | Available Thickness = XXXX | | | | | | | | |
|---------------|-------|------|------|----------------------------|------|------|------|------|------|------|------|------|
| | | | | 0080 | 0100 | 0120 | 0140 | 0180 | 0200 | 0240 | 0260 | 0300 |
| BWA-9200-XXXX | 4.83 | 2.41 | 0.89 | ○ | ○ | ○ | ○ | ○ | ○ | ○ | ○ | ○ |
| BWA-9201-XXXX | 6.10 | 2.41 | 0.89 | ○ | ○ | ○ | ○ | ○ | ○ | ○ | ○ | ○ |
| BWA-9203-XXXX | 7.37 | 2.41 | 0.89 | ○ | ○ | ○ | ○ | ○ | ○ | ○ | ○ | ○ |
| BWA-9204-XXXX | 8.64 | 3.68 | 1.02 | ○ | ○ | ○ | ○ | ○ | ○ | ○ | ○ | ○ |
| BWA-9205-XXXX | 9.91 | 3.68 | 1.02 | ○ | ○ | ○ | ○ | ○ | ○ | ○ | ○ | ○ |
| BWA-9206-XXXX | 12.45 | 4.95 | 1.14 | ○ | ○ | ○ | ○ | ○ | ○ | ○ | ○ | ○ |
| BWA-9207-XXXX | 14.99 | 4.95 | 1.14 | ○ | ○ | ○ | ○ | ○ | ○ | ○ | ○ | ○ |

0080 = 0,04" = 1.02mm = min. height
 0300 = 0,15" = 3.81mm = max. height